

# CGR - Computer Grade Electrolytic Capacitors



- High Ripple Current
- Very low ESR
- 105°C Operation
- Custom Designs Available Upon Request.
- Commercial equivalent of MIL-C-35018/04, 06, 10

### General Specifications

**Operating Temperature:**  
-40°C to +105°C with voltage

**Voltage Range:**  
7.5 WVDC to 200 WVDC

**Capacitance Range:**  
330 µF to 100,000 µF

**Capacitance Tolerance:**  
-10% +75% (7.5 - 50 WVDC)  
-10% +50% (51 - 200 WVDC)

### DC Leakage Current:

$I = 6 \times 10^{-6} CV$  after 5 minutes  
 Not to exceed 4.0mA  
 C = capacitance in µF  
 V = Rated Voltage  
 I = Leakage Current in mA

### QA Stability Test

Apply WVDC for 2000 hours at 105°C

- 105°C Capacitance change ≤ 15% from initial limits
- DC leakage current meets initial limits
- ESR ≤ 175% of initial measured value

The maximum ripple current at 85°C and 120Hz for CGR capacitors is shown in the Standard Rating Table. Maximum ripple current may be adjusted by the multipliers in the following tables:

Rated WVDC	Ripple Multipliers				
	120Hz	400Hz	1000Hz	2500Hz	10KHz
10 to 75	1.0	1.050	1.085	1.135	1.150
76 to 250	1.0	1.075	1.125	1.155	1.210

Ambient Temperature	Ripple Multipliers
+85°C	1.00
+65°C	1.42
+55°C	1.58
+45°C	1.72
+35°C	1.88
+25°C	2.00

**DuraCap International, Inc**  
 P.O. Box 1579 Woodstock, Ontario  
 N4S 0A7 Canada

**Phone:** (519) 539-4891  
**Fax:** (519) 539-6684  
<http://www.duracap.com/>



# Type CGR Dimensions and Size Charts



## Case Code Chart

Case Code	Uninsulated Can						Mounting Bracket
	Inches		mm		Inches	mm	
	D	L	D	L	C	C	
R2C	1.375	2.125	35	54	.500	12.7	VR3
R2L	1.375	2.625	35	67	.500	12.7	VR3
R3C	1.375	3.125	35	79.4	.500	12.7	VR3
R3L	1.375	3.625	35	92	.500	12.7	VR3
R4C	1.375	4.125	35	105	.500	12.7	VR3
R4L	1.375	4.625	35	117.5	.500	12.7	VR3
R5C	1.375	5.125	35	130	.500	12.7	VR3
R5L	1.375	5.625	35	143	.500	12.7	VR3
U2C	1.750	2.125	44.5	54	.750	19	VR6
U2L	1.750	2.625	44.5	67	.750	19	VR6
U3C	1.750	3.125	44.5	79.4	.750	19	VR6
U3L	1.750	3.625	44.5	92	.750	19	VR6
U4C	1.750	4.125	44.5	105	.750	19	VR6
U4L	1.750	4.625	44.5	117.5	.750	19	VR6
U5C	1.750	5.125	44.5	130	.750	19	VR6
U5L	1.750	5.625	44.5	143	.750	19	VR6
V2C	2.000	2.125	50.8	54	.875	22.2	VR8
V2L	2.000	2.625	50.8	67	.875	22.2	VR8
V3C	2.000	3.125	50.8	79.4	.875	22.2	VR8
V3L	2.000	3.625	50.8	92	.875	22.2	VR8
V4C	2.000	4.125	50.8	105	.875	22.2	VR8
V4L	2.000	4.625	50.8	117.5	.875	22.2	VR8
V5C	2.000	5.125	50.8	130	.875	22.2	VR8
V5L	2.000	5.625	50.8	143	.875	22.2	VR8
W3C	2.500	3.125	63.5	79.4	1.125	28.6	VR10
W3L	2.500	3.625	63.5	92	1.125	28.6	VR10
W4C	2.500	4.125	63.5	105	1.125	28.6	VR10
W4L	2.500	4.625	63.5	117.5	1.125	28.6	VR10
W5C	2.500	5.125	63.5	130	1.125	28.6	VR10
W5L	2.500	5.625	63.5	143	1.125	28.6	VR10
X3L	3.000	3.625	76.2	92	1.250	31.7	VR12
X4C	3.000	4.125	76.2	105	1.250	31.7	VR12
X4L	3.000	4.625	76.2	117.5	1.250	31.7	VR12
X5C	3.000	5.125	76.2	130	1.250	31.7	VR12
X5L	3.000	5.625	76.2	143	1.250	31.7	VR12
X5R	3.000	5.875	76.2	149	1.250	31.7	VR12
X6L	3.000	6.625	76.2	168	1.250	31.7	VR12
X7L	3.000	7.625	76.2	194	1.250	31.7	VR12
X8L	3.000	8.625	76.2	219	1.250	31.7	VR12
Y3L	3.500	3.625	88.9	92	1.25	31.7	N/A
Y4C	3.500	4.125	88.9	105	1.25	31.7	N/A
Y4L	3.500	4.625	88.9	117.5	1.25	31.7	N/A
Y5C	3.500	5.125	88.9	130	1.25	31.7	N/A
Y5L	3.500	5.625	88.9	143	1.25	31.7	N/A
Y5R	3.500	5.875	88.9	149	1.25	31.7	N/A
Y6L	3.500	6.625	88.9	168	1.25	31.7	N/A
Y7L	3.500	7.625	88.9	194	1.25	31.7	N/A
Y8L	3.500	8.625	88.9	219	1.25	31.7	N/A

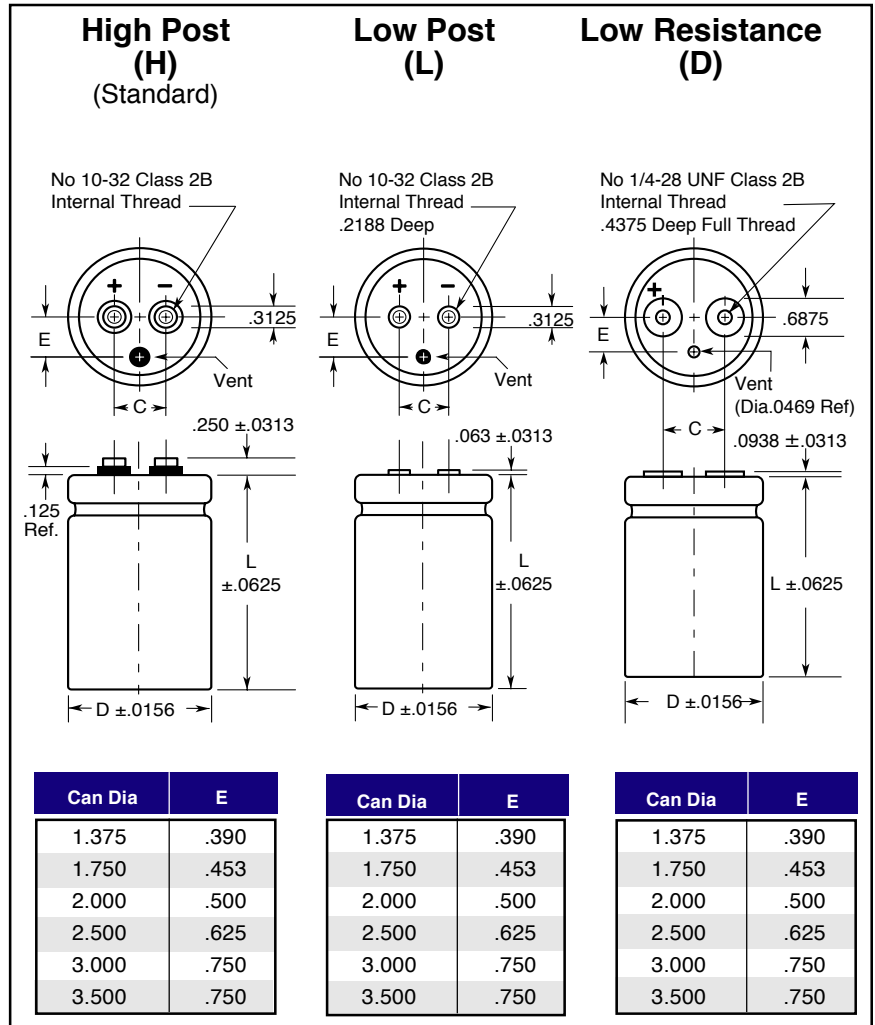

Can Dia	E	Can Dia	E	Can Dia	E
1.375	.390	1.375	.390	1.375	.390
1.750	.453	1.750	.453	1.750	.453
2.000	.500	2.000	.500	2.000	.500
2.500	.625	2.500	.625	2.500	.625
3.000	.750	3.000	.750	3.000	.750
3.500	.750	3.500	.750	3.500	.750

Add .015 inches to diameter and .045 inches to length for PVC insulating sleeve.

## PC Mounting Board Dimensions

Case Code	Uninsulated Can						
	Inches						
	D	L	H	A	B	C	E
R1N	1.375	1.750	1.937	.550	.375	.500	.250
R2C	1.375	2.125	2.312	.550	.375	.500	.250
R2L	1.375	2.625	2.812	.550	.375	.500	.250
R3C	1.375	3.125	3.312	.550	.375	.500	.250
R3L	1.375	3.625	3.812	.550	.375	.500	.250
R4C	1.375	4.125	4.312	.550	.375	.500	.250
R4L	1.375	4.625	4.812	.550	.375	.500	.250
R5C	1.375	5.125	5.312	.550	.375	.500	.250
R5L	1.375	5.625	5.812	.550	.375	.500	.250
V2C	2.000	2.125	2.312	1.000	.575	.800	.400
V2L	2.000	2.625	2.812	1.000	.575	.800	.400
V3C	2.000	3.125	3.312	1.000	.575	.800	.400
V3L	2.000	3.625	3.812	1.000	.575	.800	.400
V4C	2.000	4.125	4.312	1.000	.575	.800	.400
V4L	2.000	4.625	4.812	1.000	.575	.800	.400
V5C	2.000	5.125	5.312	1.000	.575	.800	.400
V5L	2.000	5.625	5.812	1.000	.575	.800	.400

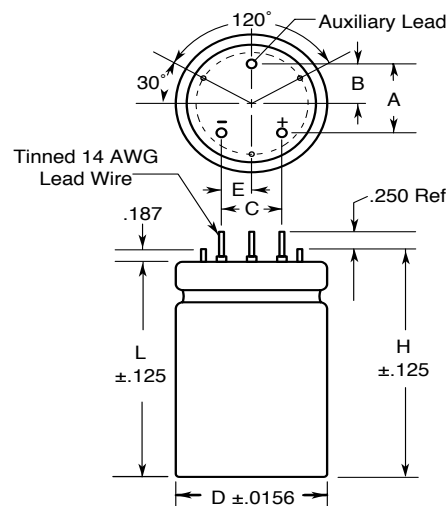

# Selector Guide & Performance Specifications

## Computer Grade Capacitors



Type	Temperature Range	VDC Range	Life Test Hours @°C	High Cap	Low ESR	Low Hi-Freq. Imped.	High Ripple	Long Life	Low Cost	Comment
CGS / CGH	-40°C to +85°C	10 to 500	1000 +85	Good	Good	Good	Good		Best	Max Cap, Best Value Standard Life & Ripple
CG	-40°C to +85°C	10 to 450	2000 +85	Best		Good	Good		Good	Max Cap, Long Life Max Ripple, Low ESR
HES	-40°C to +105°C	350 to 400	1000 +105	Good	Good	Good	Good	Good	Good	Motor Control, Ultra High Ripple High Voltage
CGR	-40°C to +105°C	7.5 to 200	2000 +105	Good	Good	Good	Good	Good	Good	Wide Temperature Range, MIL-C-39018/04, 06, 10 equivalent
CGO	-40°C to +85°C	5 to 55	1000 +85		Best				Good	Lowest ESR

**Storage:** From -55°C to maximum operating temperature up to 200,000 feet above sea level.

## Test Conditions

**Surge Test:** Connect capacitor in series with resistor as follows:

- C = 0 - 2500 $\mu$ F R = 1000 $\Omega$
- C = 2500 - 25k $\mu$ F R = 500 $\Omega$
- C =  $\geq$ 25,001 $\mu$ F R = 100 $\Omega$

Subject the series combination to rated surge voltage. For capacitors rated at +85°C, apply surge voltage for 30 seconds. Allow capacitor to discharge through resistor. Apply voltage again after 9.5 minutes. Repeat 10 minute cycle for 24 hours. For capacitors rated at +105°C, apply voltage for 30 seconds and off for 5.5 minutes for 1,000 cycles. Following surge test, allow capacitors to cool to room temperature and measure DCL. DCL is not to increase from initial requirement and no electrolyte shall have leaked.

**Load Life Test:** Use a circulating air oven set to capacitor(s) maximum operating temperature. Separate capacitors to maintain temperature -0°C +3°C. Apply rated VDC for rated life  $\pm$ 12 hours using regulated power supply free from turn-on / turn-off voltage transients. At end of test, return capacitors to room temperature for 24 hours (minimum).

DCL is not to exceed initial requirement.  
Capacitance must not be less than 85% of initial measured value.  
ESR must not be greater than:

Type	% of Initial Requirement
CGS / CGH	175
CG / HES	175
CGR	100
CGO	175

**Full Ripple Life Test:** Use a circulating air oven as in Load Life Test. Apply DC voltage with rated ripple current from AC source and reduce DC voltage unit sum of DC voltage and peak AC voltage equals capacitor's rated voltage. At end of life test return capacitors to room temperature for 24 hours (minimum). Capacitance, ESR and DCL must meet Load Life Test requirements.

**Shelf Life Test:** Use a circulating air oven as above for rated shelf life  $\pm$ 6 hours. Allow capacitors to cool to room temperature and stabilize for a minimum of 16 hours. Capacitance, ESR and DCL will meet initial requirements.

**Vibration:** Clamp capacitor to a vibrating platform and subject it to a simple harmonic motion with a maximum peak-to-peak amplitude of 0.06" and maximum acceleration of 10g. Vary the frequency linearly between 10 and 55Hz. Entire range of 10-55Hz must be traversed in one minute. Vibrate capacitor for 1-1/2 hours with the direction of motion being parallel to the axis of the capacitor. Then move the capacitor so the direction of motion is perpendicular to the axis of the capacitor and continue the vibration for an additional 1-1/2 hours. During the last 30 minutes of the test connect the capacitor to a bridge and observe for 3 minutes. There will be no evidence of loosening of the capacitor element within the case when shaken by hand following the test. No indication of intermittent contact, open or shorting is allowed during the 3 minute observation period.

**Container Seal:** Following the vibration test, each capacitor for seal tightness as follows:

Subject the capacitors to two successive temperature cycles in circulating air. One temperature cycle is:

- A. 85°C for 30 minutes
- B. 25°C for 30 minutes
- C. -40°C for 30 minutes
- D. 25°C for 30 minutes

Following the second cycle, immerse the capacitor in 90-95°C water for five minutes. A failure is a continuous chain of bubbles when immersed.

**Vent Test:** Apply reverse DC voltage to a capacitor at 15-25 Amperes. If the capacitor is open or shorts and the vent has not operated, test additional capacitors. The vent must operate and there must be no explosion.

**Shelf Life:** Capacitors stored more than 5 years should be checked for DCL to see if they meet requirements. Apply rated VDC for 30 minutes through a 1000 $\Omega$  resistor to bring DCL within limits.

**Voltage Reversal:** Capacitors will withstand a maximum 1.5 VDC reverse bias.

**Mounting:** The preferred mounting for large computer grade capacitors is in the vertical position with the pressure relief vent up or horizontal with the pressure relief valve up. Be sure to allow 1/2 inch (minimum) clearance to permit the vent to operate.

Capacitance ( $\mu\text{F}$ )	Max ESR (Ohms) @120Hz	Max Ripple Amps RMS @120Hz +85°C	Diameter	Length	Part Description
<b>7.5 WVDC; 12 VDC Surge</b>					
34,000	0.0128	14.4	1.750	3.125	CGR343U7R5U3C
47,000	0.0098	17.8	2.000	3.125	CGR473U7R5V3C
66,000	0.0068	23.8	2.000	4.125	CGR663U7R5V4C

<b>10 WVDC; 12 VDC Surge</b>					
24,000	0.0110	9.5	1.375	3.125	CGR243U010R3C

<b>12 WVDC; 15 VDC Surge</b>					
12,000	0.0154	10.6	1.375	2.625	CGR123U012R2L
100,000	0.0043	30.0	2.500	5.125	CGR104U012W5C

<b>16 WVDC; 20 VDC Surge</b>					
7,700	0.0231	7.9	1.375	2.125	CGR772U016R2C
11,000	0.0161	10.3	1.375	2.625	CGR113U016R2L
14,000	0.0119	12.9	1.375	3.125	CGR143U016R3C
16,000	0.0173	11.6	1.750	2.625	CGR163U016U2L
20,000	0.0084	17.2	1.375	4.125	CGR203U016R4C
30,000	0.0098	17.8	2.000	3.125	CGR303U016V3C
42,000	0.0075	22.7	2.000	4.125	CGR423U016V4C
51,000	0.0085	22.0	2.500	3.125	CGR513U016W3C

<b>20 WVDC; 30 VDC Surge</b>					
4,600	0.0220	8.1	1.375	2.125	CGR462U020R2C
10,000	0.0110	14.6	1.375	3.625	CGR103U020R3L
21,000	0.0090	19.7	2.000	3.625	CGR213U020V3L

Capacitance ( $\mu$ F)	Max ESR (Ohms) @120Hz	Max Ripple Amps RMS @120Hz +85°C	Diameter	Length	Part Description
------------------------	-----------------------	----------------------------------	----------	--------	------------------

30 WVDC; 45 VDC Surge					
-----------------------	--	--	--	--	--

2,200	0.0350	5.9	1.375	1.875	CGR222U030R1N
4,900	0.0250	10.3	1.750	2.125	CGR492U030U2C
7,400	0.0110	14.6	1.375	3.625	CGR742U030R3L
10,000	0.0080	18.9	1.375	4.625	CGR103U030R4L
12,000	0.0100	17.8	2.000	3.125	CGR123U030V3C
15,000	0.0090	19.7	2.000	3.625	CGR153U030V3L
27,000	0.0050	30.0	2.000	5.625	CGR273U030V5L
30,000	0.0060	29.1	2.500	4.125	CGR303U030W4C

40 WVDC; 60 VDC Surge					
-----------------------	--	--	--	--	--

2,100	0.0250	7.7	1.375	2.125	CGR212U040R2C
3,900	0.0130	12.2	1.375	3.125	CGR392U040R3C
5,600	0.0090	16.6	1.375	4.125	CGR562U040R4C
7,400	0.0100	12.3	1.375	5.125	CGR742U040R5C
9,600	0.0090	19.7	2.000	3.625	CGR962U040V3L
13,000	0.0070	25.0	2.000	4.625	CGR133U040V4L
22,000	0.0060	30.0	2.500	4.625	CGR223U040W4L
31,000	0.0050	30.0	3.000	4.625	CGR313U040X4L

50 WVDC; 75 VDC Surge					
-----------------------	--	--	--	--	--

1,000	0.1001	3.5	1.375	1.875	CGR102U050R1N
1,500	0.0672	4.7	1.375	2.125	CGR152U050R2C
2,900	0.0357	7.4	1.375	3.125	CGR292U050R3C
4,100	0.0180	8.3	1.375	4.125	CGR412U050R4C
6,200	0.0168	14.0	1.375	5.625	CGR622U050R5L
7,600	0.0165	13.7	2.000	3.125	CGR762U050V3C
10,000	0.0113	18.5	2.000	4.125	CGR103U050V4C
16,000	0.0085	24.2	2.000	5.625	CGR163U050V5L
21,000	0.0077	26.8	2.500	4.625	CGR213U050W4L
27,000	0.0060	30.0	2.500	5.625	CGR273U050W5L
37,000	0.0051	30.0	3.000	5.625	CGR373U050X5L

Capacitance (µF)	Max ESR (Ohms) @120Hz	Max Ripple Amps RMS @120Hz +85°C	Diameter	Length	Part Description
<b>75 WVDC; 100 VDC Surge</b>					
1,200	0.0497	5.9	1.375	2.625	CGR122T075R2L
1,800	0.0329	8.2	1.375	3.625	CGR182T075R3L
2,000	0.0220	6.7	1.375	3.125	CGR202U075R3C
2,200	0.0200	7.9	1.375	4.125	CGR222T075R4C
3,100	0.0350	11.0	2.000	2.625	CGR312T075V2L
4,100	0.0140	10.9	1.750	4.125	CGR412T075U4C
4,700	0.0150	15.2	2.000	3.625	CGR472T075V3L
7,500	0.0095	16.2	2.000	5.625	CGR752U075V5L
8,000	0.0085	16.4	2.500	3.625	CGR802T075W3L
9,600	0.0094	23.2	2.500	4.125	CGR962T075W4C
11,000	0.0102	23.8	3.000	3.625	CGR113T075X3L
19,000	0.0056	30.0	3.000	5.625	CGR193T075X5L
<b>100 WVDC; 135 VDC Surge</b>					
330	0.0940	2.8	1.375	2.125	CGR331T100R2C
2,700	0.0120	18.8	2.000	4.625	CGR272T100V4L
4,500	0.0094	24.3	2.500	4.625	CGR452T100W4L
8,000	0.0085	21.8	3.000	5.625	CGR802T100X5L
<b>200 WVDC; 250 VDC Surge</b>					
3,500	0.0240	11.5	3.000	4.125	CGR352T200X4C
5,200	0.0170	15.4	3.000	5.625	CGR522T200X5L